

SFT1440



Yixinwei Technology
http://szyxwkj.com

N-Channel Power MOSFET 600V, 1.5A, 8.1Ω, Single TP/TP-FA

Features

- ON-resistance $R_{DS(on)}=6.2\Omega(\text{typ.})$
- Protection diode in

Specifications

Absolute Maximum Ratings at $T_a=25^\circ\text{C}$

Parameter	Symbol	Conditions	Ratings	Unit
Drain-to-Source Voltage	V_{DSS}		600	V
Gate-to-Source Voltage	V_{GSS}		± 30	V
Drain Current (DC)	I_D		1.5	A
Drain Current ($PW \leq 10\mu\text{s}$)	I_{DP}	$PW \leq 10\mu\text{s}$, duty cycles $\leq 1\%$	6.0	A
Allowable Power Dissipation	P_D		1.0	W
		$T_c=25^\circ\text{C}$	20	W
Channel Temperature	T_{ch}		150	$^\circ\text{C}$
Storage Temperature	T_{stg}		-55 to +150	$^\circ\text{C}$

Stresses exceeding Maximum Ratings may damage the device. Maximum Ratings are stress ratings only. Functional operation above the Recommended Operating Conditions is not implied. Extended exposure to stresses above the Recommended Operating Conditions may affect device reliability.

Package Dimensions unit : mm (typ) 7518-004

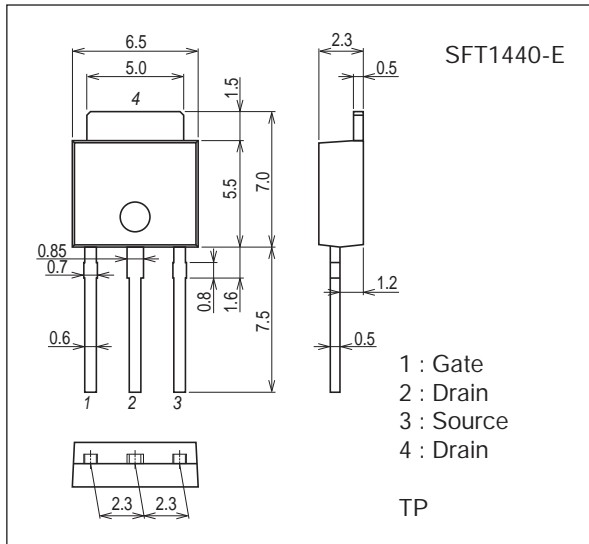

Package Dimensions unit : mm (typ) 7003-004

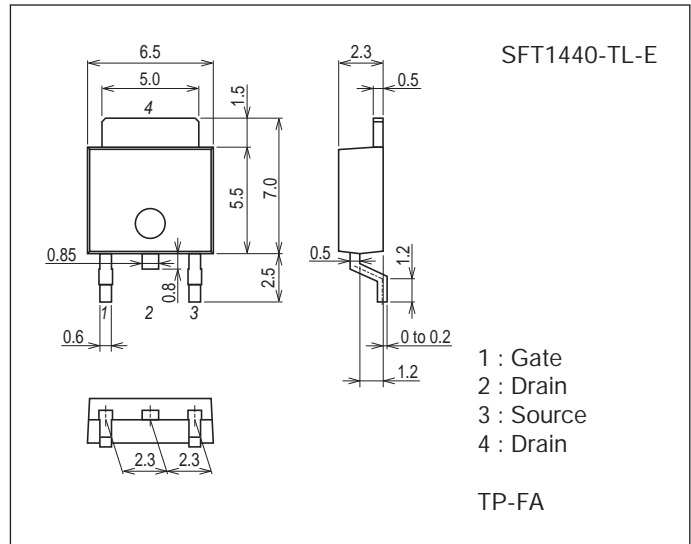

Product & Package Information

- Package : TP
- JEITA, JEDEC : SC-64, TO-251
- Minimum Packing Quantity : 500 pcs./bag

Marking (TP, TP-FA)

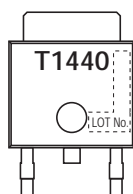

- Package : TP-FA
- JEITA, JEDEC : SC-63, TO-252
- Minimum Packing Quantity : 700 pcs./reel

Packing Type (TP-FA) : TL

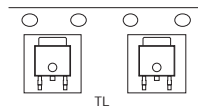

Electrical Connection (TP, TP-FA)

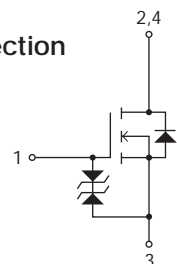

SFT1440

Electrical Characteristics at Ta=25°C

Parameter	Symbol	Conditions	Ratings			Unit	
			min	typ	max		
Drain-to-Source Breakdown Voltage	$V_{(BR)DSS}$	$I_D=10mA, V_{GS}=0V$	600			V	
Zero-Gate Voltage Drain Current	I_{DSS}	$V_{DS}=480V, V_{GS}=0V$			100	μA	
Gate-to-Source Leakage Current	I_{GSS}	$V_{GS}=\pm 24V, V_{DS}=0V$			± 10	μA	
Cutoff Voltage	$V_{GS(off)}$	$V_{DS}=10V, I_D=1mA$	3.0		5.0	V	
Forward Transfer Admittance	$ y_{fs} $	$V_{DS}=10V, I_D=0.8A$		1.0		S	
Static Drain-to-Source On-State Resistance	$R_{DS(on)1}$	$I_D=0.8A, V_{GS}=10V$		6.2	8.1	Ω	
Input Capacitance	C_{iss}	$V_{DS}=30V, f=1MHz$		130		pF	
Output Capacitance	C_{oss}				25		pF
Reverse Transfer Capacitance	C_{rss}				4.0		pF
Turn-ON Delay Time	$t_{d(on)}$				9.1		ns
Rise Time	t_r	See specified Test Circuit.		15		ns	
Turn-OFF Delay Time	$t_{d(off)}$				18		ns
Fall Time	t_f				19		ns
Total Gate Charge	Q_g	$V_{DS}=300V, V_{GS}=10V, I_D=1.5A$		6.3		nC	
Gate-to-Source Charge	Q_{gs}				1.4		nC
Gate-to-Drain "Miller" Charge	Q_{gd}				3.6		nC
Diode Forward Voltage	V_{SD}	$I_S=1.5A, V_{GS}=0V$		0.85	1.2	V	

Switching Time Test Circuit

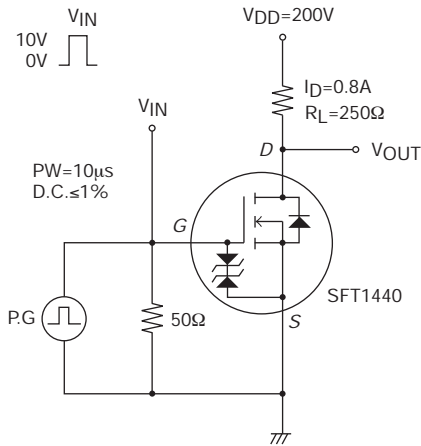

Ordering Information

Device	Package	Shipping	memo
SFT1440-E	TP	500pcs./bag	Pb Free
SFT1440-TL-E	TP-FA	700pcs./reel	

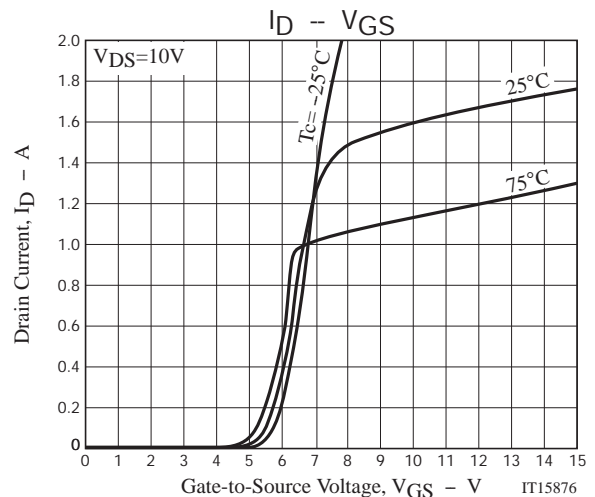
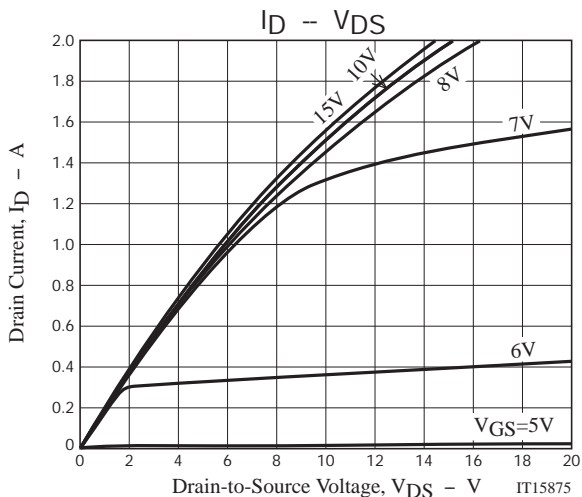

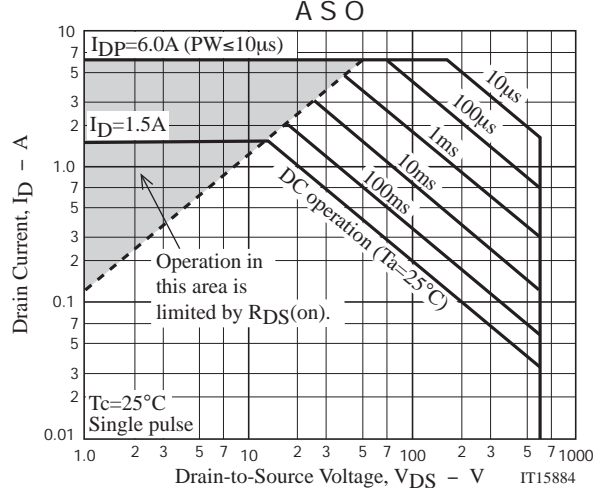
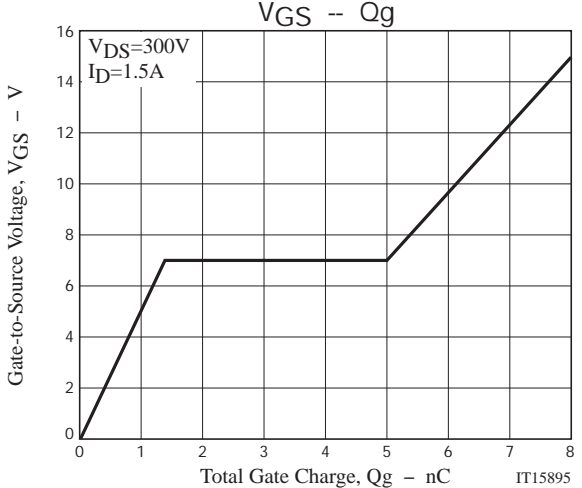
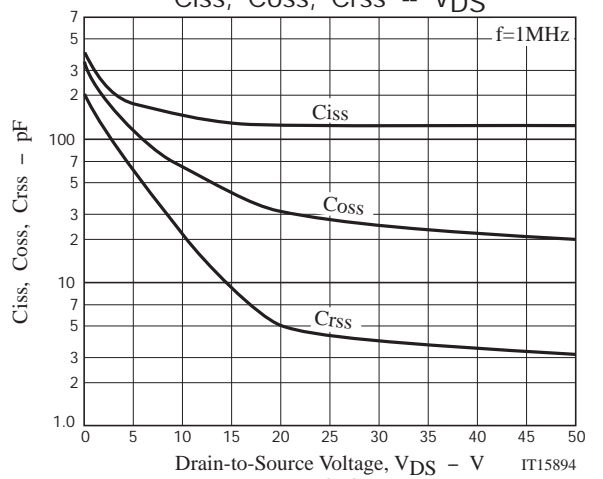
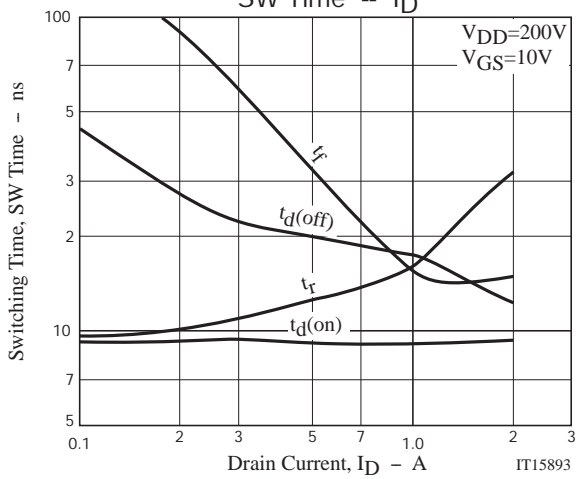
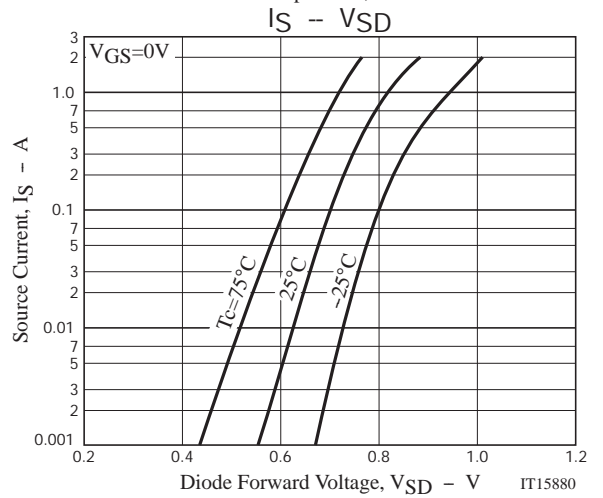
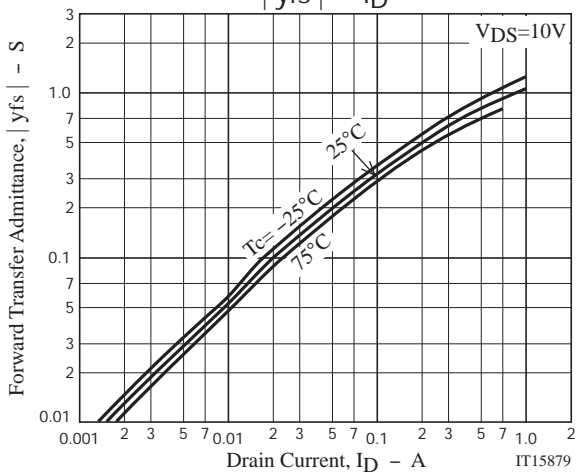
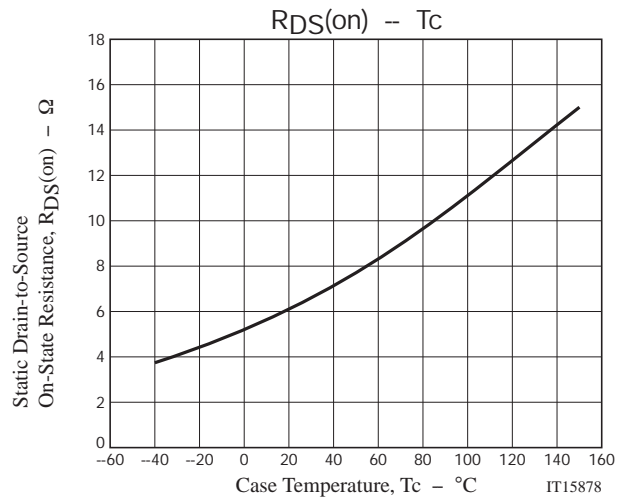
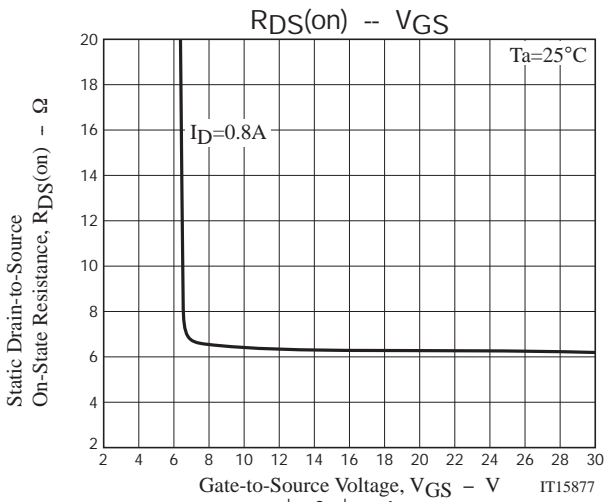

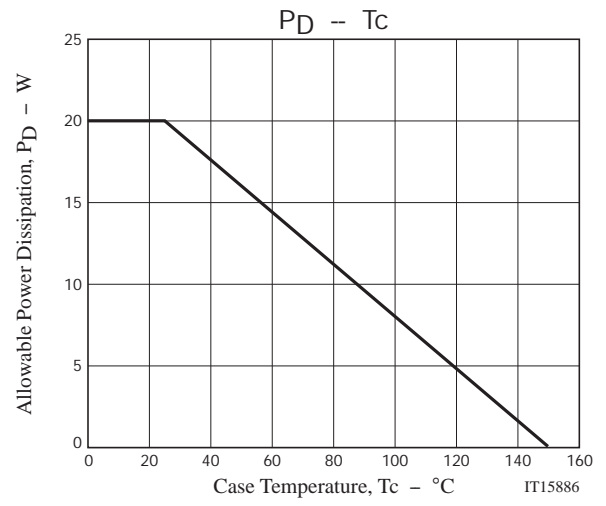
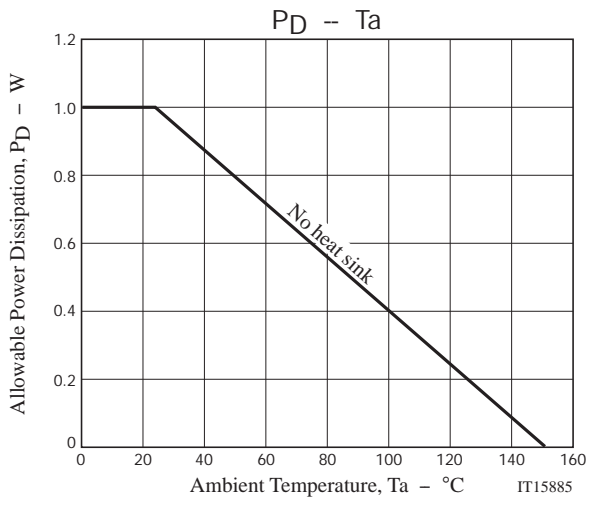

Taping Specification

SFT1440-TL-E

Packing Format

Package Name	Carrier Tape Type	Maximum Number of devices contained (pcs)			Packing format	
		Reel	Inner box	Outer box	Inner BOX (C-1)	Outer BOX (A-7)
TP-FA	TP	700	2,100	12,600	3 reels contained Dimensions:mm (external) 183×72×185	6 inner boxes contained Dimensions:mm (external) 440×195×210

Packing method

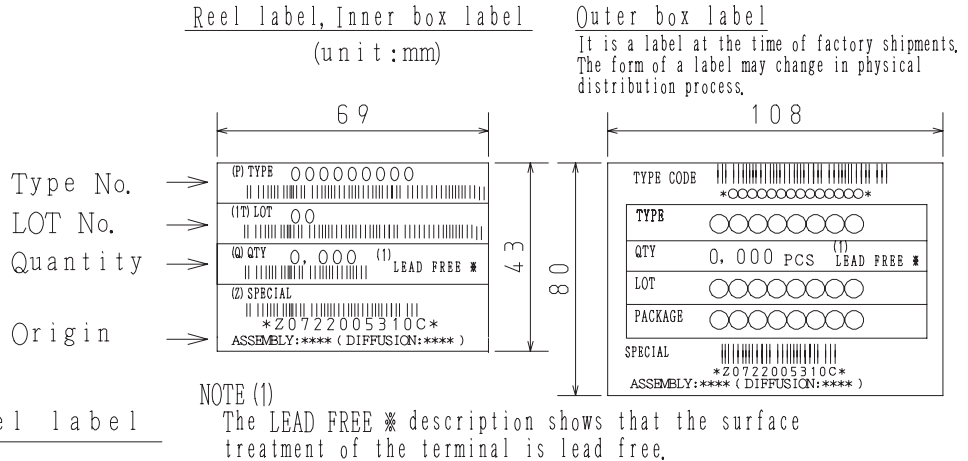
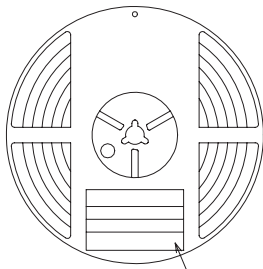

NOTE (1)

The LEAD FREE # description shows that the surface treatment of the terminal is lead free.

Label	JEITA Phase
LEAD FREE 3	JEITA Phase 3A
LEAD FREE 4	JEITA Phase 3

Taping configuration

1. Carrier tape size (unit:mm)

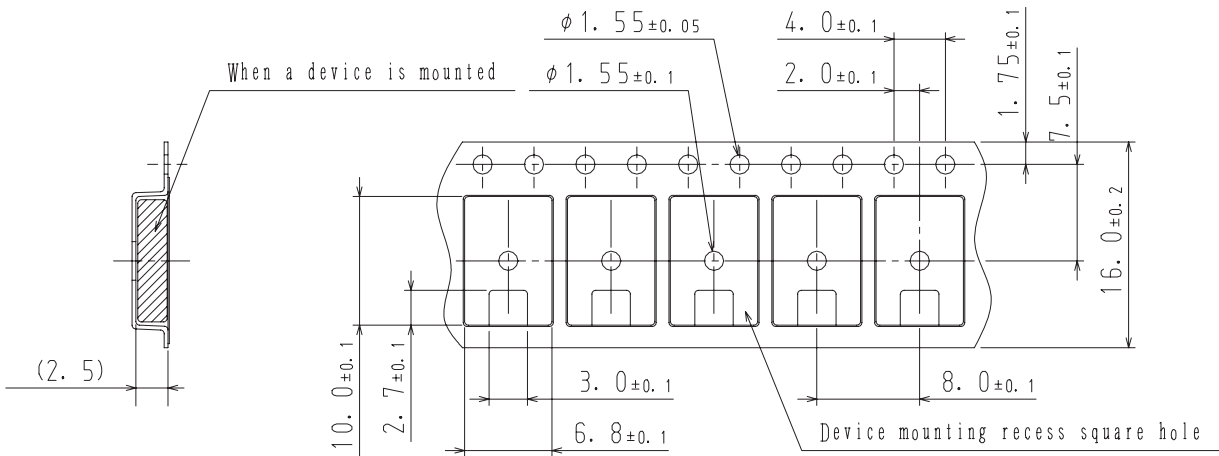

2. Device placement direction

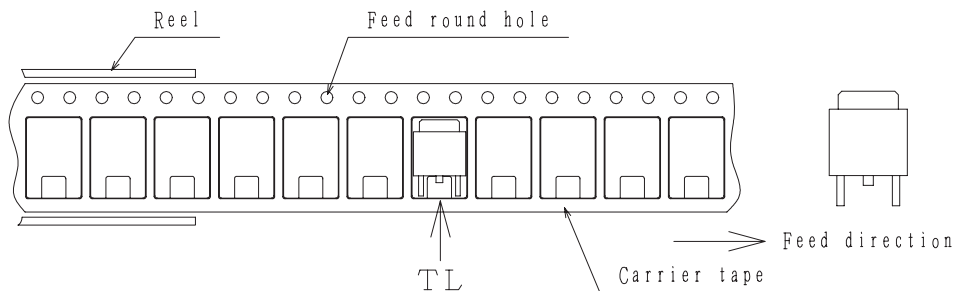

Those with one electrode terminal on the feed hole side.....TL

SFT1440

Outline Drawing SFT1440-TL-E

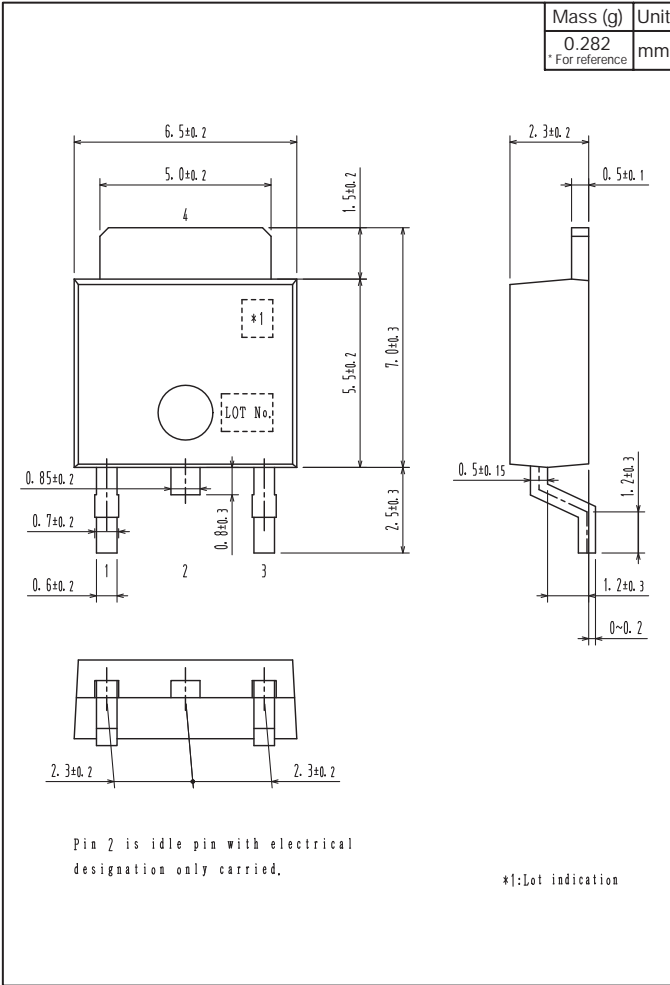

Land Pattern Example

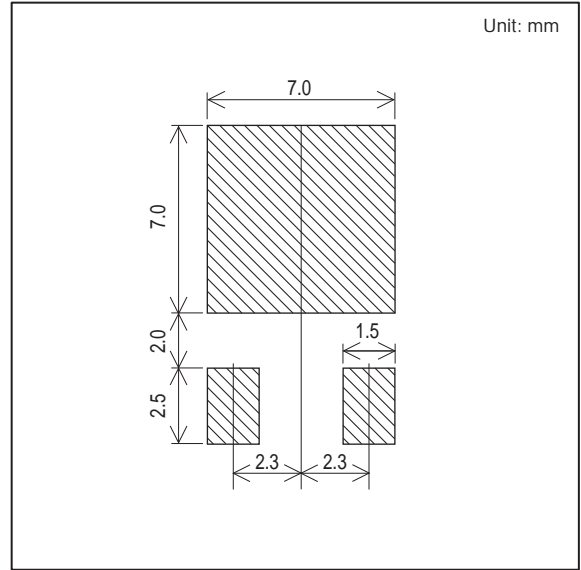

Bag Packing Specification

SFT1440-E

1. Packing Format

Package Name	Maximum Number of devices contained (pcs)			
	Bag	Inner box	Outer box	
TP	500	B-1	A-1	A-2
		10,000	50,000	30,000
Packing format (Dimensions:mm (external))				
		Inner box	Outer box	
		B-1	A-1	A-2
		445×225×55	470×250×300	470×250×190

2. Bag dimensions
(unit:mm)

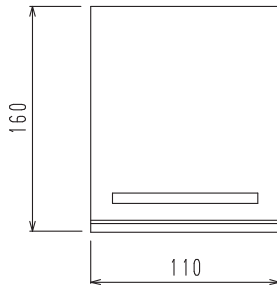

3. Bag label, Inner box label
(unit:mm)

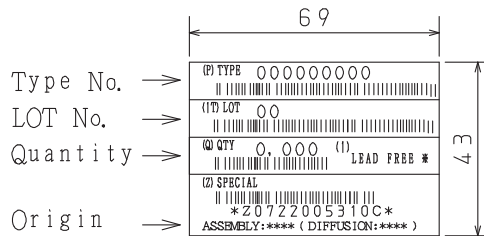

4. Outer box label
(unit:mm)

It is a label at the time of factory shipments.
The form of a label may change in physical distribution process.

NOTE (1)

The LEAD FREE * description shows that the surface treatment of the terminal is lead free.

Label	JEITA Phase
LEAD FREE 3	JEITA Phase 3A
LEAD FREE 4	JEITA Phase 3

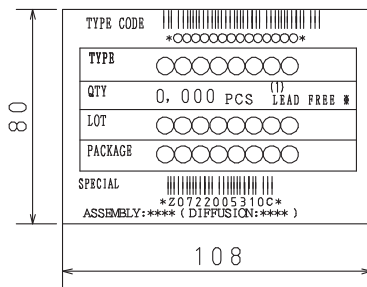

Outline Drawing

SFT1440-E

